

TORSIONALLY RIGID AND FLEXIBLE

BELLOWS COUPLINGS

SERIES BKZ | 20 – 1,000 Nm



R+W[®]
COUPLING TECHNOLOGY

THE ULTIMATE COUPLING FROM 20 – 1,000 Nm

www.rw-america.com



MODEL BKZ

BACKLASH-FREE, TORSIONALLY STIFF METAL BELLOWS COUPLINGS

rigid and flexible, with clamping hub

Properties:

- double flex bellows, for high misalignment compensation
- easy to mount
- low moment of inertia

Material:

Bellows made of highly flexible high-grade stainless steel. Hub material see table.

Design:

With a single ISO 4762 radial clamping screw per hub.

Self opening clamp system optional: Loosening the clamping screw applies force to the pin, which will force the clamp into the open position for easy mounting and dismounting.

Absolutely backlash-free due to frictional clamping connection.

Temperature range:

-30 to +100° C (-22 F to 212 F)

Speeds:

Standard up to 6,000 rpm

Option: In excess of 6,000 rpm with a finely balanced version (contact R+W)

Service life:

These couplings have an infinite life and are maintenance-free if the technical ratings are not exceeded.

Tolerance:

On the hub/shaft connection 0.01 to 0.05 mm.

Non standard:

Custom designs with varied tolerances, keyways, non-standard material, bellows and ATEX designs are available upon request.



TGA-ZM-05-91-00
Registration No. 40503432/2

The information mentioned in this document is based on our present knowledge and experiences and does not exclude the manufacturer's own substantial testing of the equipment. So this is no obligatory assurance even with regard to protection rights of Third Parties. The sale of our products is subject to our General Conditions of Sale and Delivery.



R+W America
1120 Tower Lane
Bensenville, IL 60106
Phone: 630-521-9911
Fax: 630-521-0366
info@rw-america.com
www.rw-america.com

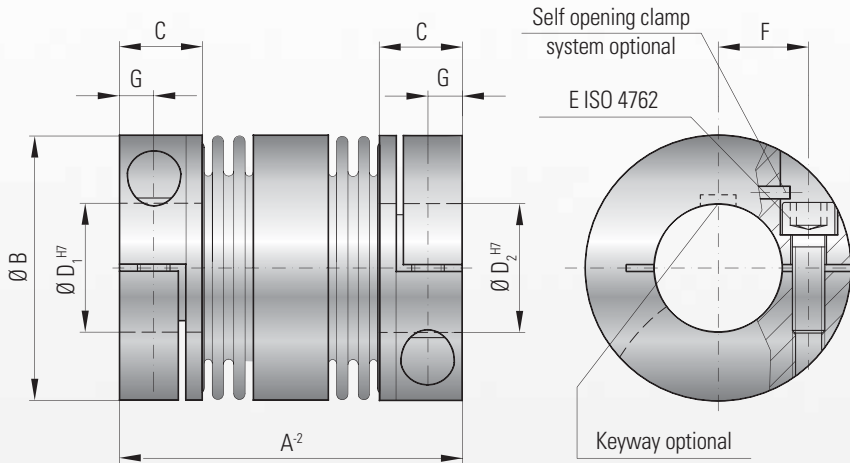

Longer versions for higher parallel misalignment compensation available upon request.

Ordering example

BKZ / 20 / 24 / 15 / XX

Model
Series Nm
Ø D1 H7
Ø D2 H7
non standard e.g. stainless steel

Model BKZ		Series			
		20	200	400	1000
Rated torque (Nm)	T_{KN}	20	200	400	1000*
Overall length coupling (mm)	A^2	82	115	150	185
Outer diameter (mm)	B	49	66	82	110
Fit length (mm)	C	16.5	23	27.5	34
Inner diameter possible from Ø to Ø H7 (mm)	$D_{1/2}$	15-28	24-35	32-40	40-60
Fastening screw ISO 4762		M5	M8	M10	M12
Tightening torque of the fastening screw (Nm)	E	8	40	60	130
Distance between centers (mm)	F	17	23	27	39
Distance (mm)	G	6	9.5	11	13
Moment of inertia (10^{-3} kgm ²)	J_1	0.09	0.44	1.3	11.7
Hub material		AL	AL	AL	steel optional AL
Approx. weight (kg)		0.23	0.62	1.2	5.6
Torsional stiffness (10^9 Nm/rad)	C_t	20.95	69	85	285
axial	± (mm)	2	3	2	4
lateral	± (mm)	0.4	0.5	0.65	0.8
angular	± (degree)	1	1	1	1
axial spring stiffness (N/mm)	C_a	27.9	76.5	57	74
lateral spring stiffness (N/mm)	C_l	1855	5500	3029	4505

* Maximum transferable torque of the coupling depends on the hub material.